



UPGRADE 

PISTA | FF CALIPERS



“More than 40 years of Competition Experience in a box”

The racing suit for your wheels

For popular track oriented cars Brembo offers complete race systems dedicated exclusively to motorsports and designed to deliver the best results when used in the most extreme conditions: consistent performance, superior braking power, precision and control, and resistance to very high temperatures.

All Brembo racing application products are the result of ongoing research and development in collaboration with the world's most prestigious teams. All of these products are designed and manufactured in-house and track tested.

PISTA



The first members of a NEW FAMILY of forged racing calipers that have been engineered to offer maximum track and race performance at reduced costs. The new family is being introduced with the FF6 and the FF4 calipers, the other calipers are expected to follow in the near future, with the aim to offer a complete range dedicated to those needing to combine track performance with competitive prices. Brembo's unmatched experience in professional racing and road-going upgrade systems contributed to the development of this new family, with the goal of offering high-level racing systems to customers at a price-point comparable to our road systems.



PISTA / **FF**



Internal
fluid path

Fixed tangential
bridge

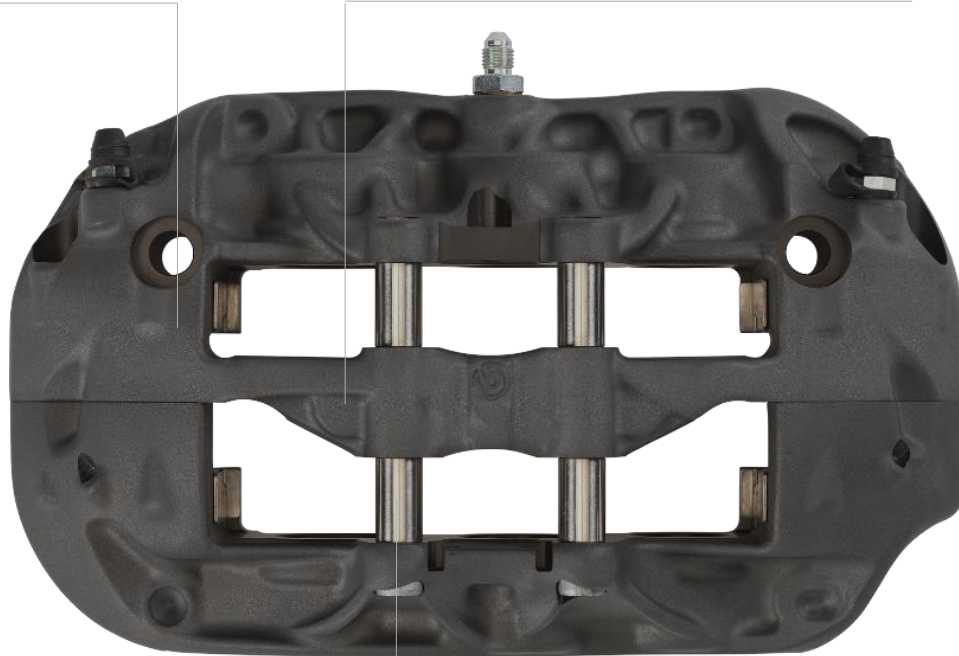

Pad quick release and
Anti-noise Kit available
upon request

Fixed tangential bridge with removable axial bridge bolts allows for maximal stiffness while allowing pad changes without removing caliper. The calipers are suitable for use with a wide range of disc sizes, and multiple pad shape options.

PISTA / **FF**



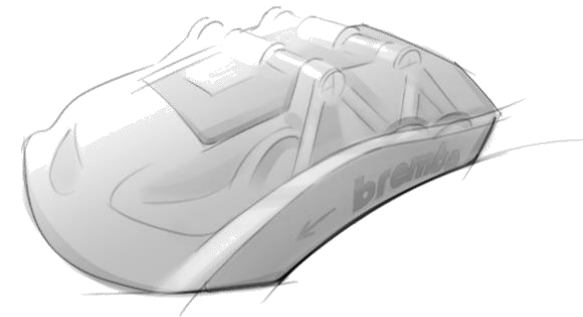

Design – The look of a monobloc caliper with the cost advantages of a 2-piece caliper. 3D forged asymmetrical body with fixed tangential bridge and removable axial bridge bolts.

Versatility – the new calipers are compatible with a wide range of disc sizes, and multiple pad shapes that are already available in the marketplace.

PISTA / **FF**



PISTA/FF6

Disc Diameter: 355 – 380 mm

Disc Thickness: 32 – 36 mm

Braking Annulus: 52 – 56 mm

Pad Area: 74 – 77.4 cm²

Pad Thickness: ≤ 18 mm

Piston Sizes: 28/32/38 mm



PISTA/FF4

Disc Diameter: 315 – 330 mm

Disc Thickness: 28 mm

Braking Annulus: 44 – 50 mm

Pad Area: 59 cm²

Pad Thickness: ≤ 16,75 mm

Piston Sizes:
28/30 mm
36/42 mm





UPGRADE 

follow us on



www.brembo.com